

# ***CBA Charge Controller***

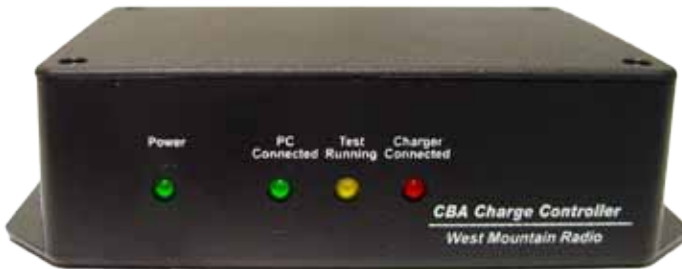

**[www.westmountainradio.com](http://www.westmountainradio.com)**

1020 Spring City Drive

Waukesha, WI 53186

262-522-6503

[sales@westmountainradio.com](mailto:sales@westmountainradio.com)

©2016 West Mountain Radio, All rights reserved. All trademarks are the property of their respective owners.

---

## Introduction

Thank you for choosing the West Mountain Radio CBA Charge Controller. It can be used with a West Mountain Radio CBA IV and a user provided battery charger to automate life cycle tests, automatically alternating between periods of charging the battery and discharging the battery. By automatically switching between charge and discharge cycles of the battery a hands-free lifetime test of the battery can be performed.

When the unit is idle, the two pairs of Powerpole® Connectors are open. When the unit is in a charging state, the two Powerpole® are connected together, connecting the user provided battery charger to the battery.

The CBA Charge Controller and software can determine when the battery is done being charged by inspecting an output signal of the user provided battery charger, which the user will have to connect to the IN-A or IN-B inputs of the CBA Charge Controller. If the user provided battery charger does not provide an external signal to signify a charge is complete, an LED on the user provided battery charger could be used instead by connecting leads from the LED to the IN-A or IN-B of the CBA charger. If the user provided battery requires a button to be pressed or other external signal to start a charge cycle, the OUT-A and OUT-B connections of the CBA Charger can be used. When the unit goes into charge cycle, the CBA Charger closes the OUT-A and OUT-B connectors. When the unit is idle, OUT-A and OUT-B are open.

## CBA Charge Controller

### Charge / Discharge Test

The CBA Charge Controller board has the following inputs and outputs:

- IN-A and IN-B: These should connect to a signal on the charging unit that indicates charging is complete. An LED will suffice. These inputs can handle up to 12V.
- OUT-A and OUT-B: These outputs are shorted (relays closed) when the software is starting a charge cycle. The purpose of this is to connect to a push-button on a charging unit, where the push button might control the start/stop of the charger.

Powerpole® is a registered trademark of [Anderson Power Products](#)

- 
- Powerpole®: When a Charge/Discharge test is not running, or during the Discharge cycle of a Charge/Discharge test, these poles will be open. During a Charge cycle, these power poles will close (short) and the CBA Charge Controller and the CBA Software can read the current drawn by the battery from the charger unit.
  - Green LED: This is lit when the CBA software has connected to the CBA Charge Controller. NOTE: There is a green power LED also.
  - Yellow LED: This is lit when the CBA software is currently performing a Charge/Discharge test. It will go dark when test is complete.
  - Red LED: This is lit when the CBA software is currently in a charging phase of a Charge/Discharge test (the power poles are closed and the charging unit is connected to the battery).

When starting a charging cycle, the CBA software will close both the OUT-A and OUT-B relays and leave them closed for the duration of the cycle. If this is not compatible with charging unit in use or if needing more flexible options, contact West Mountain Radio and support may be added to the charging unit.

While performing a charging cycle, the CBA software will look for a high on either IN-A or IN-B to signify a charge complete. If this is not compatible with the charging unit in use or if needing more flexible options, contact West Mountain Radio and added support may be added to the charging unit.

## **Typical Setup**

The CBA and battery are both connected in parallel to the indicated Powerpole® connector. When the test is in Discharge the relay on the CBA Charge Controller is open and creates an open circuit. Similarly, during charge mode, the CBA acts as an open circuit while the CBA Charge Controller relay is closed and the battery is charged. A setup diagram is shown on the next page.

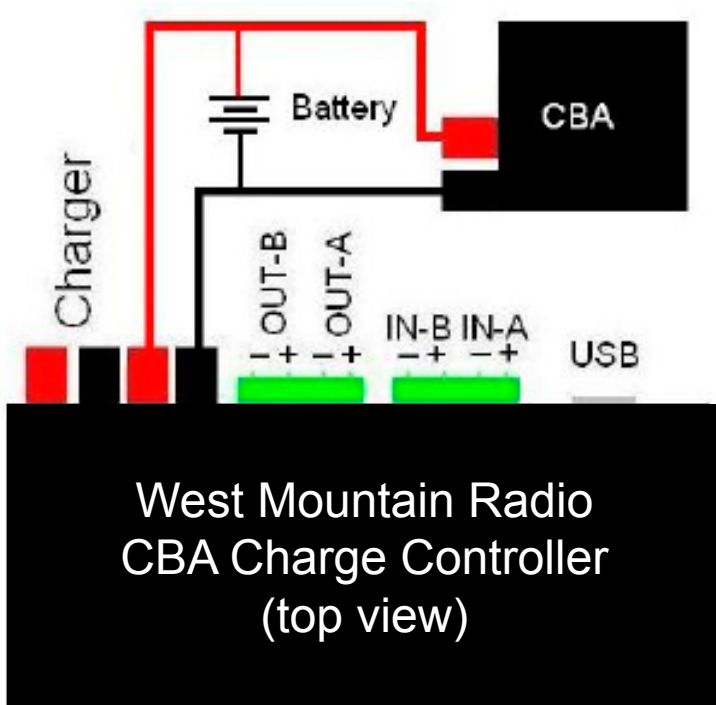

### Specifications

<b>Dimensions</b>	1.5 x 6.0 x 4.25 inches
<b>Max Voltage (Powerpole®)</b>	55 V
<b>Max Current during Charging (through Powerpole®)</b>	10 A at 24 V / 2.5 A at 55 V
<b>Max Voltage (IN-A and IN-B)</b>	50 V
<b>Min Voltage (IN-A and IN-B); min voltage required to detect asserted line</b>	3 V (IN-A and IN-B Detection assertion regardless of polarity of voltage input)
<b>Max Voltage (OUT-A and OUT-B)</b>	30 V
<b>Max Current (OUT-A and OUT-B)</b>	2 A

---

## Safety Precautions

The West Mountain Radio CBA is inherently safe but the batteries it tests are not. Anything that stores energy is potentially dangerous! Some types of batteries are safer than others but they are all capable of causing explosions or fires.

For technical information on your battery, refer to the Battery Manufacturers web site to get detailed information on the rating of your battery. Most battery labels have limited information, but the manufacturer's web site may have more detailed information. General Information on batteries is also available on your West Mountain Radio CD. Select Battery Information and FAQ's.

### Primary Safety Considerations:

- Never discharge a battery at a higher discharge rate than it is designed for.
- Never use a battery that has poorly insulated or frayed wiring or exposed metal parts.
- Never connect a battery with reverse polarity.
- Never test a battery near flammable materials.
- Never allow a battery reach a temperature that causes it to get so hot that it may be too hot to touch.
- Recharge your batteries immediately with an appropriate battery charger after you have completed your test. Some types do not like to sit discharged for extended periods of time.
- Never test or charge your batteries while unattended.
- Have a fire extinguisher nearby.

### CBA Operating Requirements:

- Never connect a battery with the polarity reversed!
- Always connect the USB cable BEFORE connecting the battery!
- Never connect a battery to the CBA that is connected to something else.
- Contact West Mountain Radio for support before connecting to a USB hub.
- Operate the CBA in a cool dry location.
- Never allow metal parts or wiring of the battery come in contact with the metal heat sink.
- Never allow the cooling fan to be blocked or jammed.
- Do not ignore the warnings that the software may give you.
- The CBA can get hot. Do not touch the metal heat sink while, or shortly after, conducting a high power test.

---

### Lead Acid Battery Safety Warnings:

There may not be a consideration while testing lead acid batteries but there certainly is while charging lead acid batteries. These batteries, especially automotive and marine types, give off explosive hydrogen gas when charged. A nearby or internal spark or flame can cause a lead acid battery to explode sending liquid acid and lead shrapnel in all directions. This is particularly dangerous and frequently causes blindness or severe scarring injuries.

Never use a standard lead acid battery without proper ventilation. Sealed lead acid batteries such as gelled or AGM (absorbed glass mat) types are much safer. Automotive and marine types are not as safe and should be used in protective ventilated housings.

Never make the last connection to a lead acid battery causing a spark on the terminal. Always connect the load or charger last, and at a safe distance away from the battery.

### NiCad, NiMh, and Alkaline Safety Warnings:

These batteries can be dangerous also. If they are shorted out, or charged or discharged at too high a rate, they can overheat and explode. A single D size NiCad cell can actually melt a 10 penny nail, don't try this!

### Lithium Safety Warnings:

Reprinted with permission of the Academy of Model Aeronautics

Words in **bold** and ( ) were added by West Mountain Radio

### Lithium Battery Fires

Lithium batteries are becoming very popular for powering the control and power systems in our models. This is true because of their very high energy density (amp-hrs/wt. ratio) compared to NiCads or other batteries. With high energy comes increased risk in their use. The, principal, risk is FIRE which can result from improper charging, crash damage, or shorting the batteries. All vendors of these batteries warn their customers of this danger and recommend extreme caution in their use. In spite of this many fires have occurred as a result of the use of Lithium Polymer batteries, resulting in loss of models, automobiles, and other property. Homes and garages and workshops have also burned. A lithium battery fire is very hot (several thousand degrees) and is an excellent initiator for ancillary (resulting) fires. Fire occurs due to contact between Lithium and oxygen in the air. It does not need any other source of ignition, or fuel to start, and burns almost explosively.

These batteries must be used in a manner that precludes ancillary fire. The following is recommended:

- Store, and charge (discharge), in a fireproof container; never in your model.

- 
- Charge (discharge), in a protected area devoid of combustibles. Always stand watch over the charging (discharging), process. Never leave the charging process unattended.
  - In the event of damage from crashes, etc, carefully remove to a safe place for at least a half hour to observe. Physically damaged cells could erupt into flame, and, after sufficient time to ensure safety, should be discarded in accordance with the instructions which came with the batteries. Never attempt to charge (discharge) a cell with physical damage, regardless of how slight.
  - Always use chargers designed for the specific purpose, preferably having a fixed setting for your particular pack. Many fires occur in using selectable/adjustable chargers improperly set. Never attempt to charge Lithium cells with a charger which is not specifically designed for charging Lithium cells. Never use chargers designed for Nickel Cadmium batteries.
  - Use charging systems that monitor and control the charge state of each cell in the pack. Unbalanced cells can lead to disaster if it permits overcharge of a single cell in the pack. If the batteries show any sign of swelling, discontinue charging, and remove them to a safe place outside as they could erupt into flames.
  - Most important: NEVER PLUG IN A BATTERY AND LEAVE IT TO CHARGE (DISCHARGE), UNATTENDED OVERNIGHT. Serious fires have resulted from this practice.
  - Do not attempt to make your own battery packs from individual cells. These batteries CANNOT be handled and charged casually such as has been the practice for years with other types of batteries. The consequence of this practice can be very serious resulting in major property damage and/ or personal harm.

### **Again Primary Safety Considerations:**

- Never discharge a battery at a higher discharge rate than it is designed for.
- Never use a battery that has poorly insulated or frayed wiring or exposed metal parts.
- Never connect a battery with reverse polarity.
- Never test a battery near flammable materials.
- Never allow a battery reach a temperature that causes it to get so hot that it may be too hot to touch.
- Recharge your batteries immediately with an appropriate battery charger after you have completed your test. Some types do not like to sit discharged for extended periods of time.
- Never test or charge your batteries while unattended.
- Have a fire extinguisher nearby.

## CBA Charge Controller Warranty

*CBA Charge Controller* is warranted against failure due to defects in workmanship or materials for one year after the date of purchase from West Mountain Radio. Warranty does not cover damage caused by abuse, accident, misuse, improper or abnormal usage, failure to follow instructions, improper installation, alteration, lightning, or other incidence of excessive voltage or current. If failure occurs within this period, return the *CBA Charge Controller* or accessory to West Mountain Radio at your shipping expense. The device or accessory will be repaired or replaced, at our option, without charge, and returned to you at our shipping expense. Repaired or replaced items are warranted for the remainder of the original warranty period. You will be charged for repair or replacement of the *CBA Charge Controller* or accessory made after the expiration of the warranty period.

West Mountain Radio shall have no liability or responsibility to customer or any other person or entity with respect to any liability, loss, or damage caused directly or indirectly by use or performance of the products or arising out of any breach of this warranty, including, but not limited to, any damages resulting from inconvenience, loss of time, data, property, revenue, or profit, or any indirect, special incidental, or consequential damages, even if West Mountain Radio has been advised of such damages.

Except as provided herein, West Mountain Radio makes no express warranties and any implied warranties, including fitness for a particular purpose, are limited in duration to the stated duration provided herein.



[www.westmountainradio.com](http://www.westmountainradio.com)  
1020 Spring City Drive, Waukesha, WI 53186  
tel 262-522-6503 fax 262-522-6504